



PERMALOC
STRUCTUREEDGE
ALUMINUM PAVER RESTRAINT

PERMALOC CORPORATION, 13505 BARRY STREET HOLLAND, MI, 49424
(800) 356-9660 PHONE: (616) 399-9600 fax: (616) 399-9770 WWW.PERMALOC.COM

ARCHITECT NOTE: CHECK OFF APPLICABLE SIZE & FINISH DESIRED:

SIZE: IN 8' (2.44M) LENGTHS

- $\frac{3}{32}$ " X $1\frac{5}{8}$ " (2.4MM X 41MM)
w/ 0.170" (4.32MM) EXPOSED TOP LIP MF BL
- $\frac{1}{8}$ " X $1\frac{5}{8}$ " (3.2MM X 41MM)
w/ 0.190" (4.83MM) EXPOSED TOP LIP MF BL
- $\frac{3}{16}$ " X $1\frac{5}{8}$ " (4.8MM X 41MM)
w/ 0.210" (5.33MM) EXPOSED TOP LIP MF BL
- $\frac{1}{8}$ " X $2\frac{1}{4}$ " (3.2MM X 57MM)
w/ 0.190" (4.83MM) EXPOSED TOP LIP MF BL
- $\frac{3}{16}$ " X $2\frac{1}{4}$ " (4.8MM X 57MM)
w/ 0.210" (5.33MM) EXPOSED TOP LIP MF BL

FINISH LEGEND:

(MF) MILL FINISH-NATURAL ALUMINUM MEETS
(BL) BLACK DURAFLEX-ELECTROSTATICALLY APPLIED
BAKED ON PAINT, MEETS AAMA 2603

NOTES:

- INSTALL PER MANUFACTURER'S "INSTALLATION GUIDELINES"
- CONNECTION BETWEEN SECTIONS TO UTILIZE MANUFACTURER'S SLIDING CONNECTOR SYSTEM.
- CORNERS: NOTCH BASE ONLY AND FORM A CONTINUOUS CORNER.
- PERMALOC STRUCTUREEDGE AS MANUFACTURED BY PERMALOC CORPORATION, HOLLAND MI.
(800) 356-9660,
(616) 399-9600
- CONTRACTOR'S NOTE:
FOR PRODUCT AND PURCHASING INFORMATION
VISIT: WWW.PERMALOC.COM

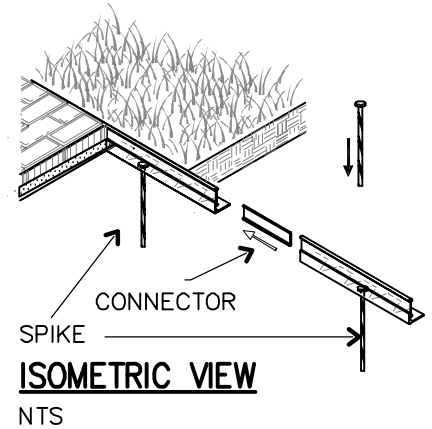
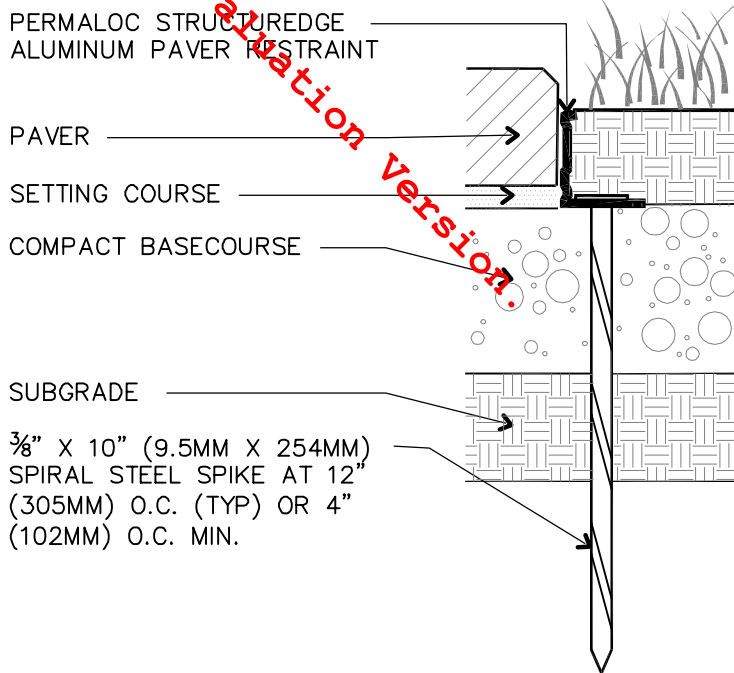

PAVER EDGE DETAIL-TYPICAL INSTALLATION

SCALE: 3"=1'-0"